

3D Shape Reasoning

To solve reasoning questions about recognising, describing and building 3D shapes.

Solve these reasoning questions.

Question 1

The opposite sides of a dice always add up to seven.
Add the missing numbers to this dice net.

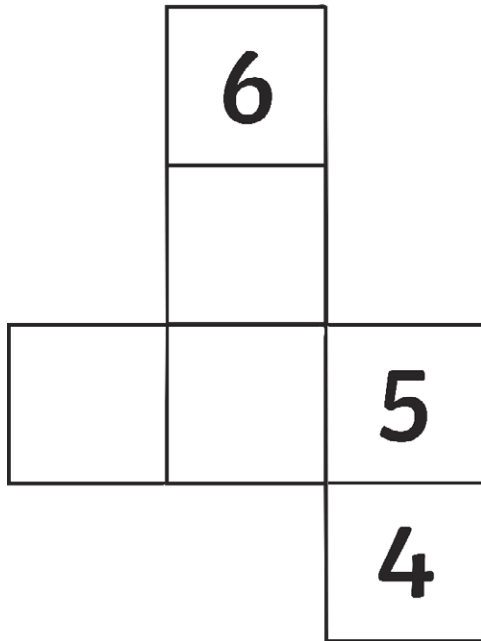

Question 2

I slice a cylinder in half. Describe the properties of each half.

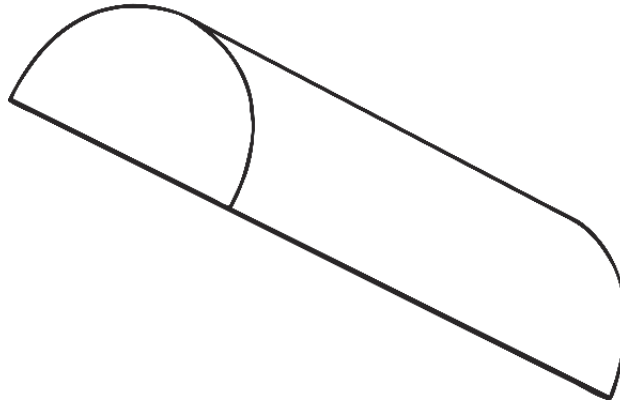

Number of faces: _____

Number of edges: _____

Numbers of vertices: _____

Question 3

How many edges does this 3D shape have?

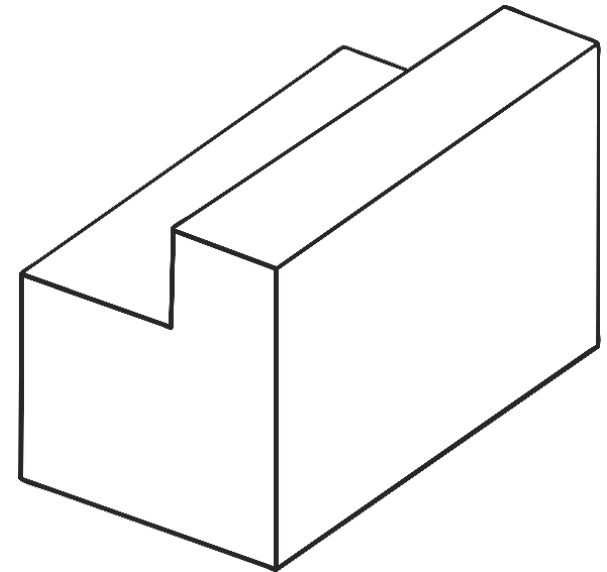

Number of edges: _____

3D Shape Reasoning

To solve reasoning questions about recognising, describing and building 3D shapes.

Solve these reasoning questions.

Question 1

The sides of a cube are marked with a horizontal stripe. Add the missing stripes to this cube net.

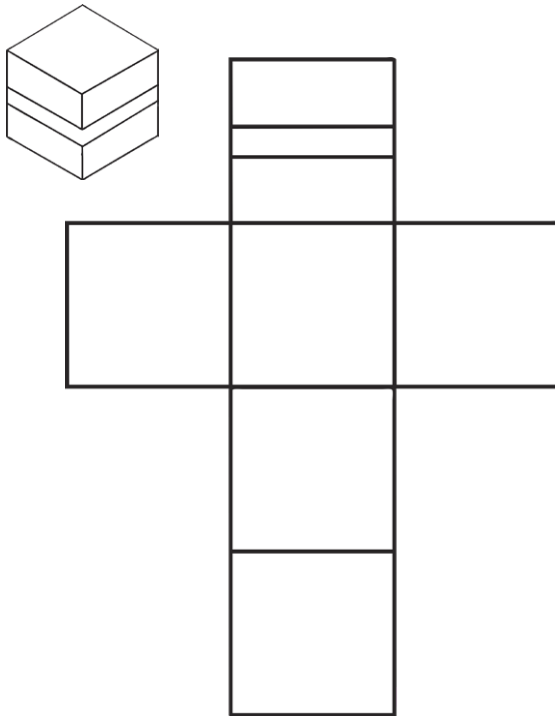

Question 2

I slice the top off a cone. Describe the properties of the new 3D shape.

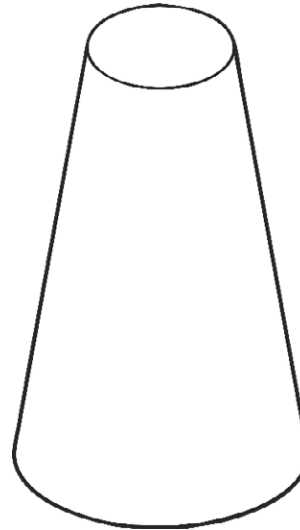

Number of faces: _____

Number of edges: _____

Numbers of vertices: _____

Question 3

I place a cuboid and a triangular prism together to make a new 3D shape. How many edges does this new shape have?

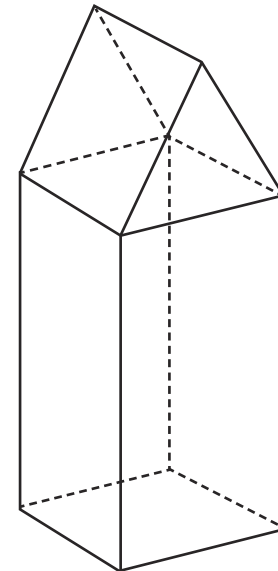

Number of edges: _____

3D Shape Reasoning

To solve reasoning questions about recognising, describing and building 3D shapes.

Solve these reasoning questions.

Question 1

A cube has shaded shapes on three of its faces. Draw the shaded shapes onto the cube net.

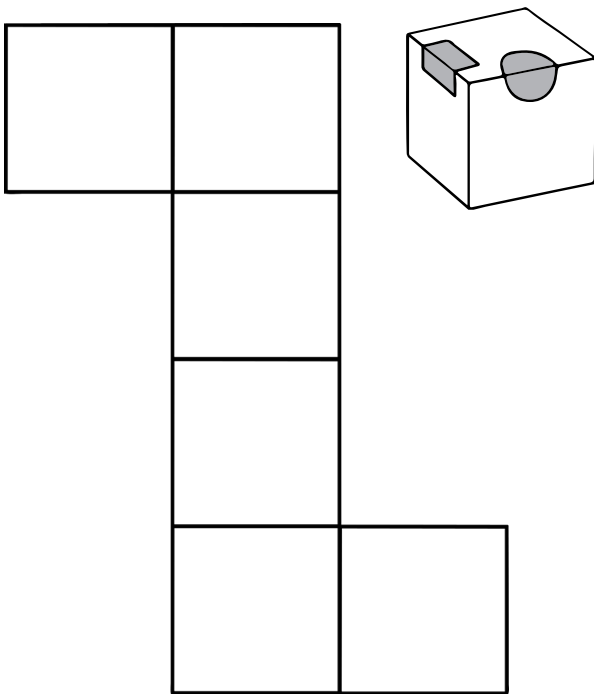

Question 2

I slice a pentagonal prism into two pieces vertically from the top vertex to create a quadrilateral prism. Describe the properties of the new 3D shape.

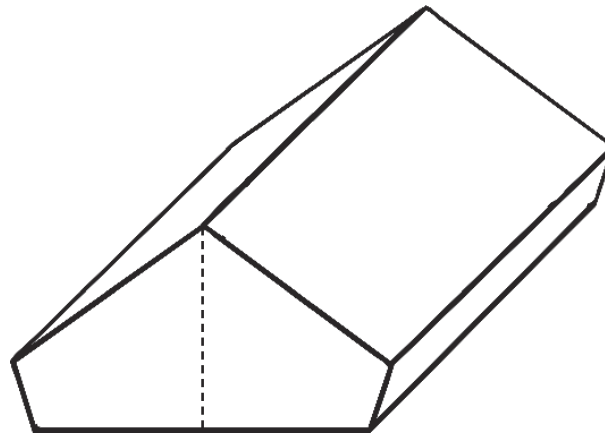

Number of faces: _____

Number of edges: _____

Numbers of vertices: _____

Question 3

I place a triangular prism and a pyramid together to make a new 3D shape. How many edges does this new shape have?



Number of edges: _____

3D Shape Reasoning **Answers**

To solve reasoning questions about recognising, describing and building 3D shapes.

Solve these reasoning questions.

Question 1

The opposite sides of a dice always add up to seven.
Add the missing numbers to this dice net.

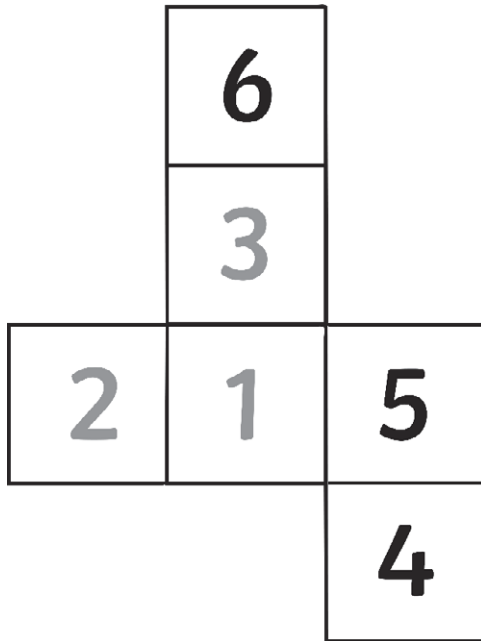

Question 2

I slice a cylinder in half. Describe the properties of each half.

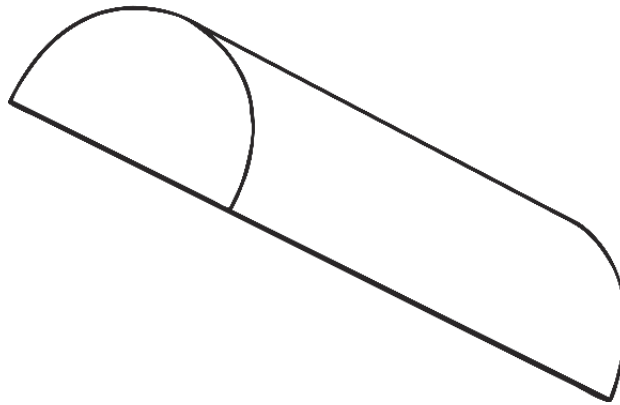

Number of faces: 4

Number of edges: 6

Numbers of vertices: 4

Question 3

How many edges does this 3D shape have?

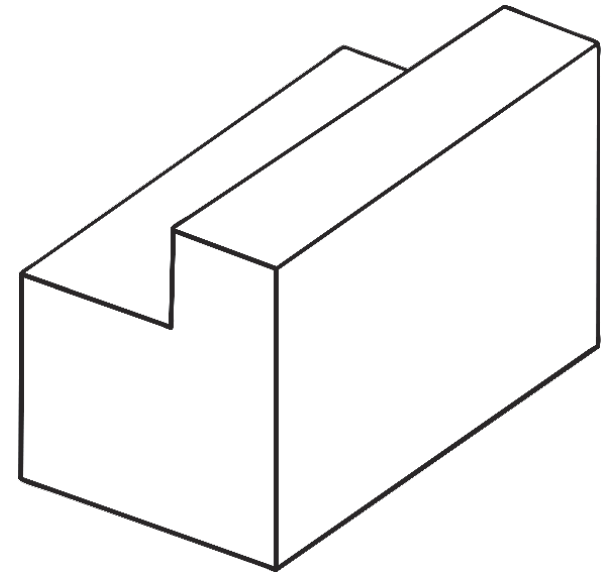

Number of edges: 18

3D Shape Reasoning **Answers**

To solve reasoning questions about recognising, describing and building 3D shapes.

Solve these reasoning questions.

Question 1

The sides of a cube are marked with a horizontal stripe. Add the missing stripes to this cube net.

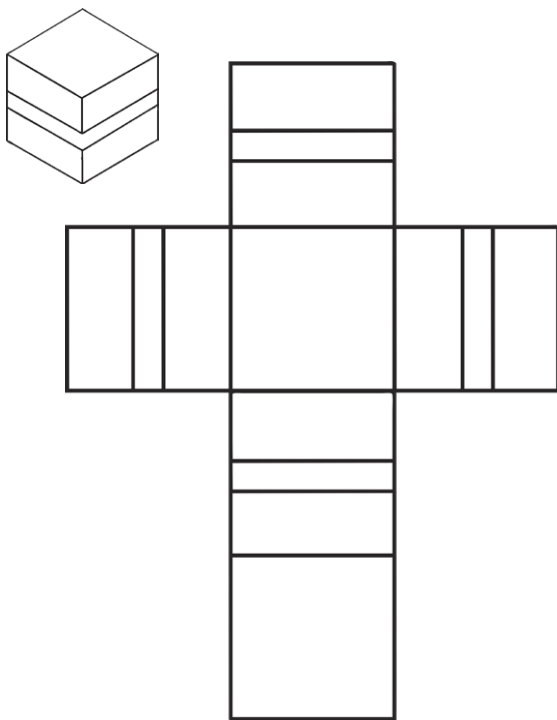

Question 2

I slice the top off a cone. Describe the properties of the new 3D shape.

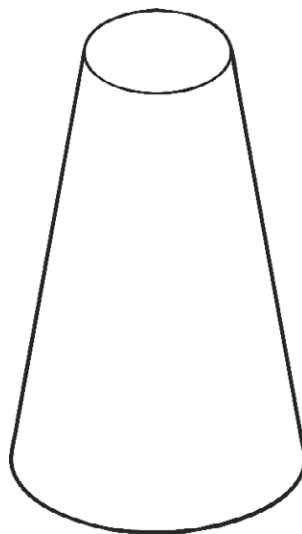

Number of faces: 3

Number of edges: 2

Numbers of vertices: 0

Question 3

I place a cuboid and a triangular prism together to make a new 3D shape. How many edges does this new shape have?

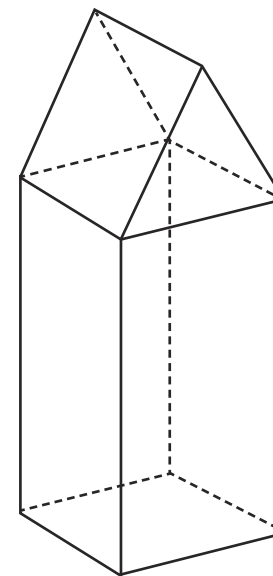

Number of edges: 17

3D Shape Reasoning Answers

To solve reasoning questions about recognising, describing and building 3D shapes.

Solve these reasoning questions.

Question 1

A cube has shaded shapes on three of its faces. Draw the shaded shapes onto the cube net.

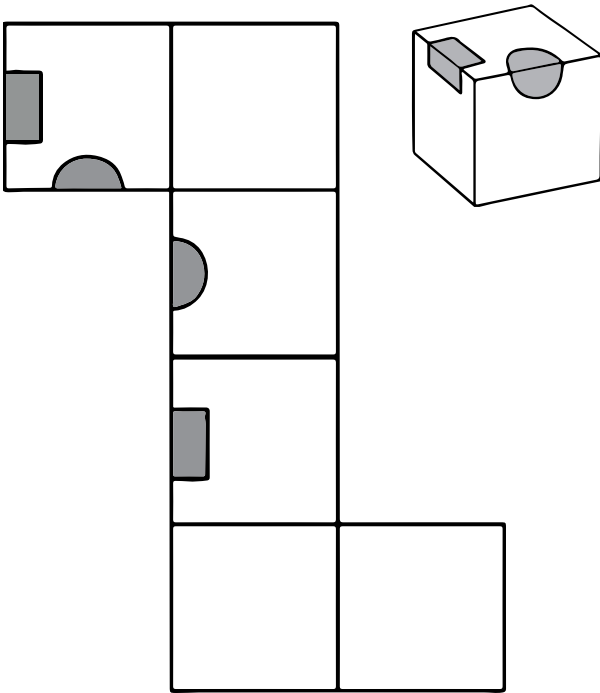

Question 2

I slice a pentagonal prism into two pieces vertically from the top vertex to create a quadrilateral prism. Describe the properties of the new 3D shape.

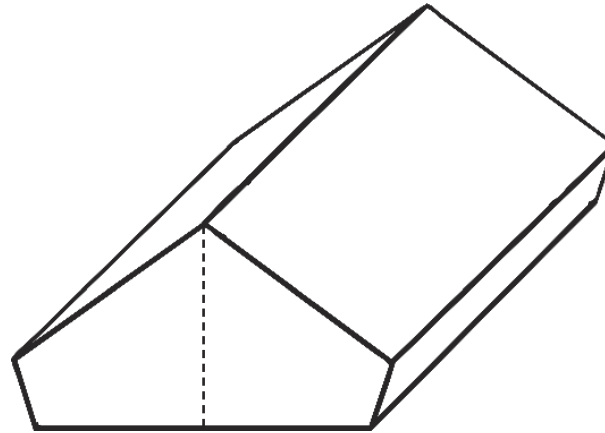

Number of faces: 6

Number of edges: 12

Numbers of vertices: 8

Question 3

I place a triangular prism and a pyramid together to make a new 3D shape. How many edges does this new shape have?



Number of edges: 12